

Installation, Operation, and Maintenance Instructions Forged Steel Globe Valves Chicago Valves Series No. 38

PARTS & MATERIAL

PART NO.	PART NAME	QTY.	MATERIAL	
1	Body	1	A105N+STL	A182 F316L+STL
2	Disc	1	A276 420	A276 316L
3	Stem	1	A276 410	A182 F316L
4	Gasket	1	304+Graphite	316L+Graphite
5	Bonnet Bolt	4	A193 B7	A193 B8M
6	Bonnet	1	A105N	A182 F316L
7	Packing	1 Group	Graphite	
8	Gland Bolt	2	A193 B7	A193 B8M
9	Gland Studs	2	A276 304	
10	Packing Flange	1	A276 420	A182 F316L
11	Gland Flange	1	A105N	A182 F304
12	Nut	2	A194 2H	A194 8M
13	Stem Nut	1	A276 410	
14	Washer	1	A276 410	
15	Nameplate	1	Aluminum	
16	Hand Wheel Nut	1	A194 2H	A194 8M
17	Hand Wheel	1	A197	

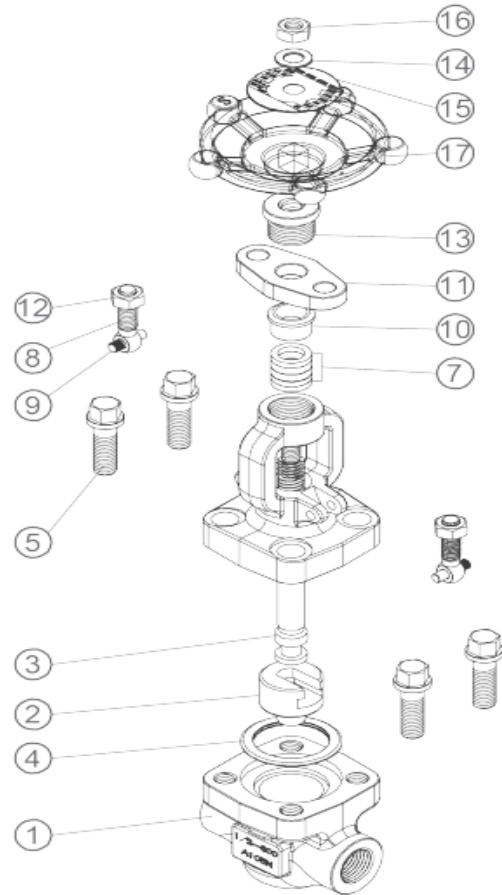

1. SAFETY INSTRUCTIONS:

2.1 Read this Installation, Operation and Maintenance Manual before using the valve. Chicago Valves cannot anticipate all the situations a user may encounter while installing and using the Chicago Valve. The user must know and follow all applicable industry specifications on the safe installation and use of these valves. Only qualified personnel or technicians who are trained for maintenance work and have read the instructions are to assemble and disassemble the valve.

2. **Operation:**

Fluids flow through globe valves in an irregular path, into the valve and upwards under the disc, then past the disc downwards and out of the valve. The disk may be positioned at any point from fully closed to fully open to regulate fluid flow through the valve. The plug-like disk is actuated by the screw and hand wheel. The valve is closed by turning the hand wheel clockwise until it hits dead end and is sitting tightly in the seat (fully closed). The stem rises when the valve is being opened by turning the hand wheel counter-clockwise until it stops (fully open).

3. **Inspection Maintenance and Disassembly:**

- 3.1 Make sure there is no pressure in the line before performing any maintenance on the valve.
- 3.2 Remove the valve from the line. Work in a clean, free of dust, debris, and well lighted area. For safety and comfort, do the repairs on a table with a vise.
- 3.3 Clamp the valve body to the vise.
- 3.4 Remove the cover bolts to separate the cover with top assembly from the body.
- 3.5 Check and replace damaged cover gaskets.
- 3.6 Examine the disc and seat surfaces for damage. Excessive wear may require replacement of the damaged component. Minor damage or wear may be repaired by re-lapping or stoning the seat faces. For valves welded in the line with damaged seats, repair of the seats is very difficult or impossible. Valves may have to be replaced.

4. **Reassembly:**

- 4.1 Reassemble the valve in the reverse order of disassembly.